

HANDHOLE

CONDUIT SPECIFICATIONS

1. FOR TRAFFIC SIGNALS ALL CONDUIT SHALL BE PVC.
2. CONDUIT FOR FIBER SHALL BE PVC PLASTIC.
3. TRACER WIRE WILL BE INSTALLED IN ALL CONDUITS FOR LOCATING PURPOSED.
4. ALL EMPTY CONDUITS WILL HAVE A PULL STRING.
5. CONDUIT WILL BE 24 INCHES DEEP TO THE TOP AT GRADE.
6. A MIN 30 FEET OF WIRE SHALL BE COILED IN ALL HANDHOLES (NOT LOOPED THROUGH).

PREPARED BY: DLZ INDIANA, LLC



Brian M. Smith
2/1/2022

APPROVED/REVISED BY THE BOARD OF PUBLIC WORKS & SAFETY



CITY OF MISHAWAKA, INDIANA

ENGINEERING STANDARDS

| ITEM | REVISION | APPROVED DATE |
|------|--------------|---------------|
| | ADOPTED: NEW | MARCH 2013 |
| | REVISED | FEBRUARY 2022 |
| | | |
| | | |

TRAFFIC/COMMUNICATIONS
HANDHOLE

SHT. NO.

IX-1

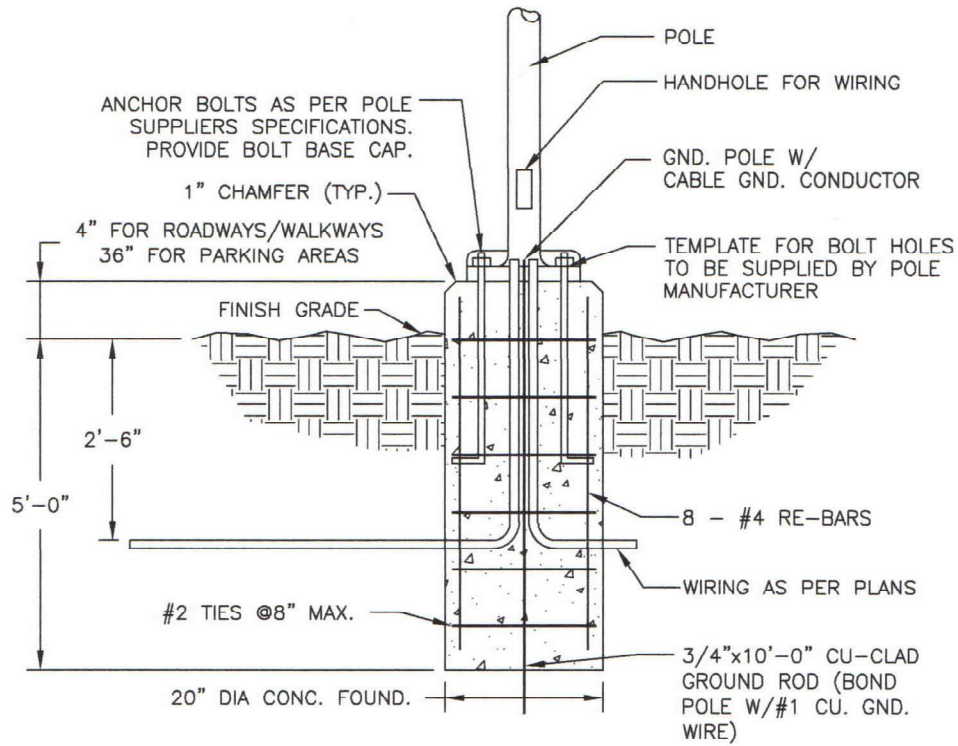

**20" LIGHT POLE FOUNDATION
FOR MAXIMUM 20' POLE HEIGHT
N.T.S.**

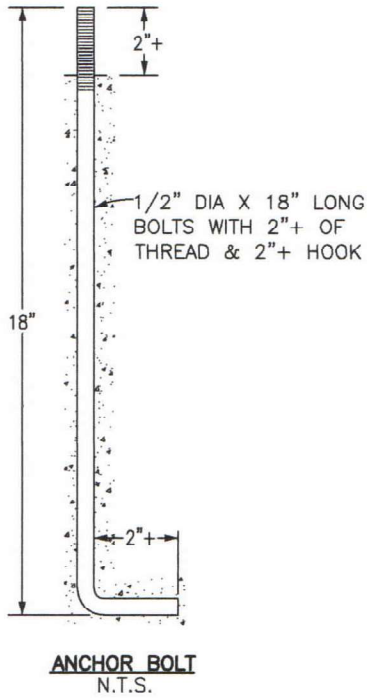

**ANCHOR BOLT
N.T.S.**

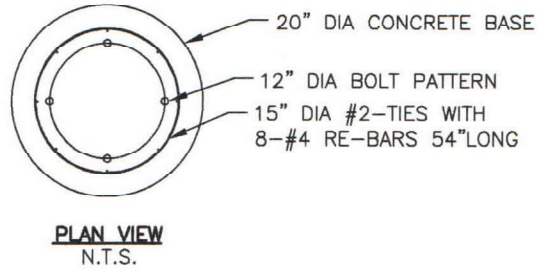

**PLAN VIEW
N.T.S.**

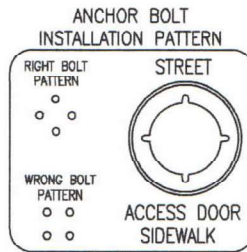

NOTES:

- CONSULT THE LIGHT POLE MANUFACTURER FOR A FULL SIZE TEMPLATE AND FOR EXACT SPECIFICATIONS FOR THE INSTALLATION.

PREPARED BY: DLZ INDIANA, LLC

Wayne A. Truef
2-2-22

| | | | |
|--|-----------|---------------|---|
| APPROVED/REVISED BY THE BOARD OF PUBLIC WORKS & SAFETY | | | CITY OF MISHAWAKA, INDIANA |
| ITEM | REVISION | APPROVED DATE | |
| | EFFECTIVE | APRIL 2007 | ENGINEERING STANDARDS |
| | REVISED | FEBRUARY 2008 | |
| | REVISED | FEBRUARY 2022 | |
| | | | |
| | | | STREET LIGHT FOUNDATION DETAIL |
| | | | SHT. NO. IX-2 |

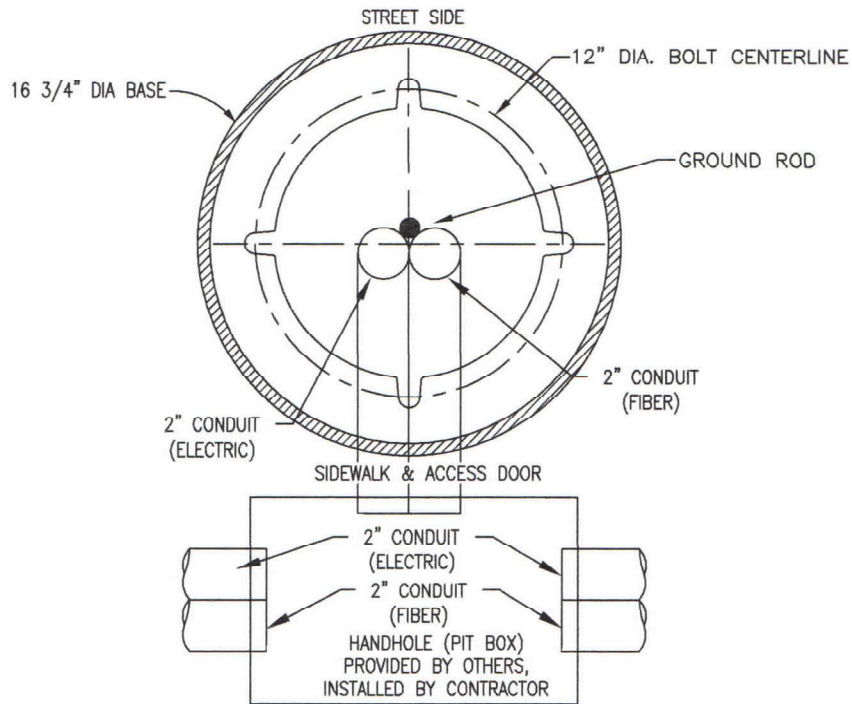

STANDARD STREET LIGHT POLE BASE AND HANDHOLE
N.T.S.

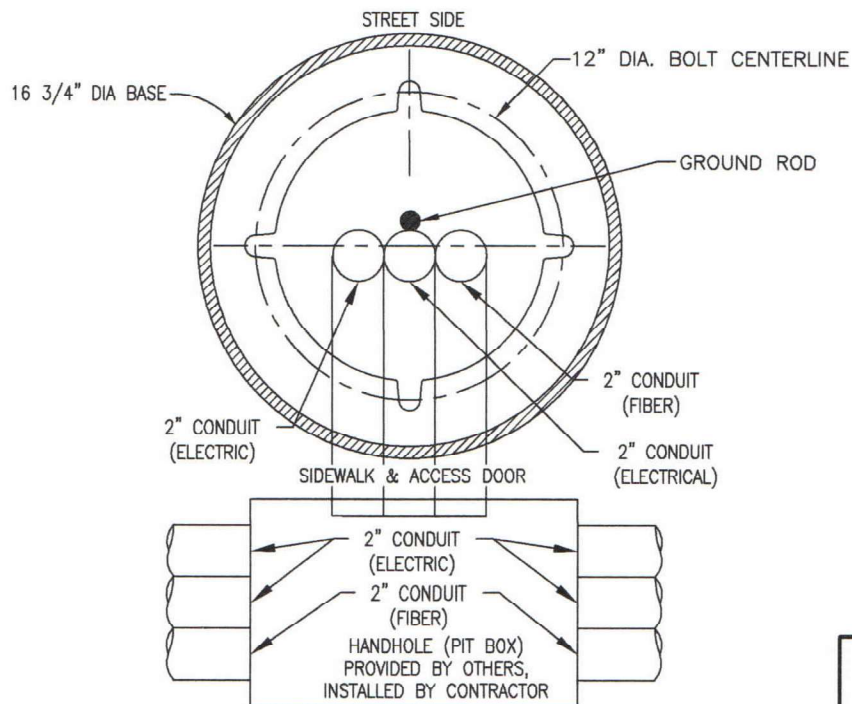

MODIFIED STREET LIGHT POLE BASE AND HANDHOLE
N.T.S.

NOTES:

- CONSULT THE LIGHT POLE MANUFACTURER FOR A FULL SIZE TEMPLATE AND FOR EXACT SPECIFICATIONS FOR THE INSTALLATION.

PREPARED BY: DLZ INDIANA, LLC



Wayne A. Trux
2-2-22

APPROVED/REVISED BY THE BOARD OF PUBLIC WORKS & SAFETY



CITY OF MISHAWAKA, INDIANA

| ITEM | REVISION | APPROVED DATE |
|------|--------------|---------------|
| | ADOPTED: NEW | FEBRUARY 2022 |
| | | |
| | | |

ENGINEERING STANDARDS

STREET LIGHT
ELECTRICAL DETAILS

SHT. NO.

IX-3

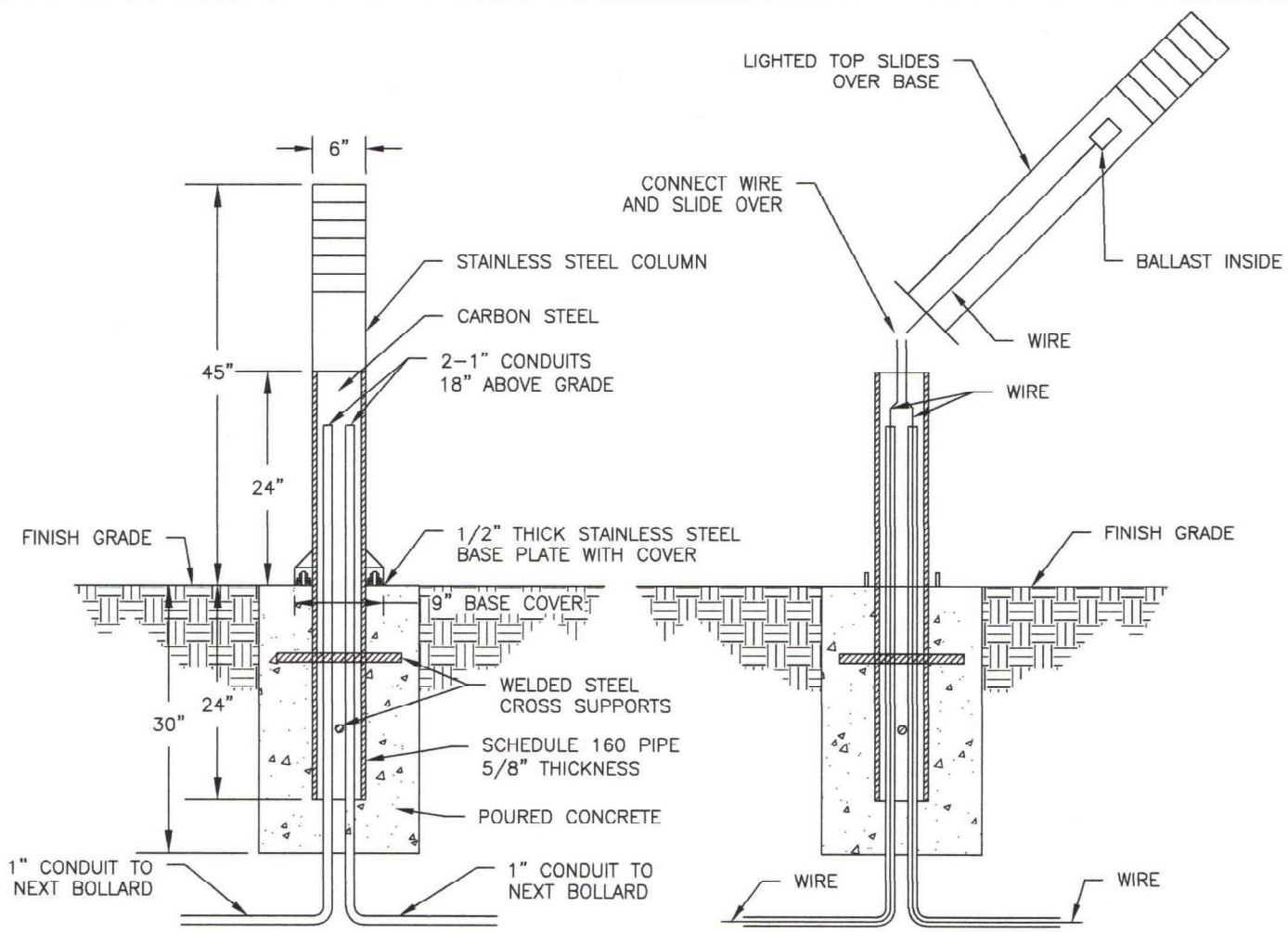

LIGHTED BOLLARD DETAIL
N.T.S.

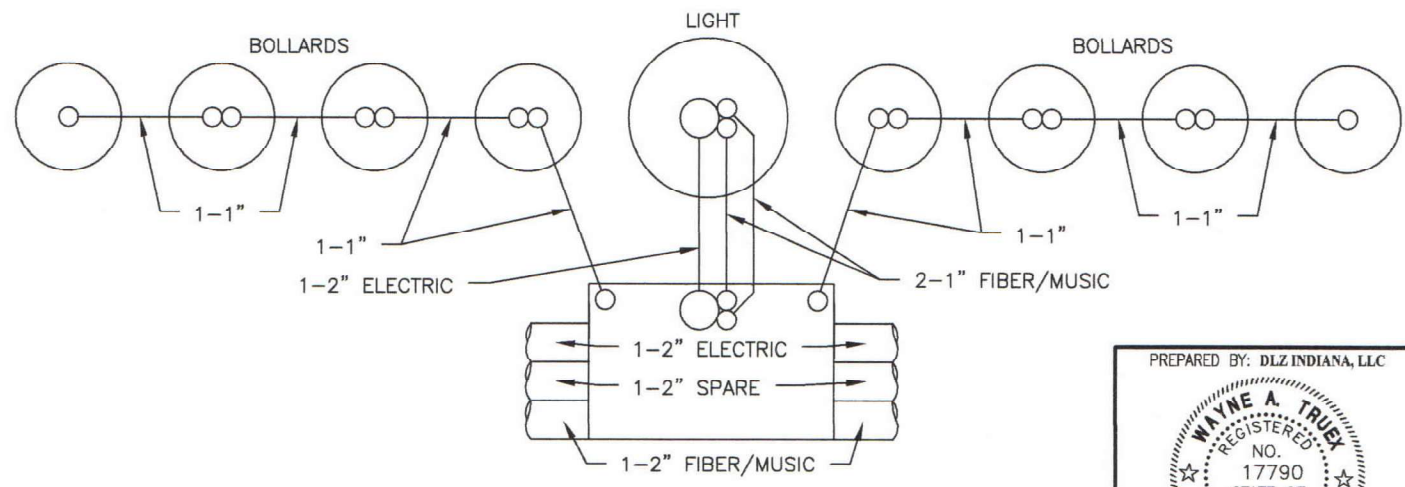

LIGHTED BOLLARD HANDHOLE
N.T.S.

PREPARED BY: DLZ INDIANA, LLC

WAYNE A. TRUFX
REGISTERED
NO. 17790
STATE OF
INDIANA
PROFESSIONAL ENGINEER

Wayne A. Trufox
2-2-22

| | | | | | |
|--|--------------|---------------|--|----------------------------|--|
| APPROVED/REVISED BY THE BOARD OF PUBLIC WORKS & SAFETY | | |  | CITY OF MISHAWAKA, INDIANA | |
| ITEM | REVISION | APPROVED DATE | | ENGINEERING STANDARDS | |
| | ADOPTED: NEW | | FEBRUARY 2022 | LIGHTED BOLLARD DETAIL | |
| | | | | SHT. NO. IX-4 | |